

## For Finished Ceiling Installations Requiring:

- Clear Voice Announcements
- Full range music reproduction, even at background levels

## Features:

- Smooth hemispherical coverage pattern
- Flat frequency response
- Accurate, full range voice and music reproduction without electronic processing
- High sensitivity (89dB 1W/1m)
- Fewer units produce results superior to conventional ceiling loudspeakers
- Exclusive patented Broadband Linear Excursion Control for high sensitivity and accurate, articulate low frequency performance
- Exclusive patented Exponential Diffusion Control for smooth mid and high frequencies throughout the coverage area at any volume level
- Integral transformer for 25V, 70V and 100V constant voltage systems
- Unit shipped fully assembled
- Uses standard tile bridge for 8" speakers

*The Model Q-CS specifications are subject to improvement and modification. Log on to [www.soundsphere.com](http://www.soundsphere.com) for updated specifications or call (203)386-9200 for updated literature.*

## SOUNDSPHERE®

### Division of Sonic Systems, Inc.

10 Research Drive, Stratford, CT 06615  
 (203) 386-9200 • Fax: (203) 386-0773  
 Web: [www.soundsphere.com](http://www.soundsphere.com)

## Q-Series

## MODEL Q-CS LOUDSPEAKER

### Applications:

- Office Buildings
- Restaurants
- Bars/Nightclubs
- Hotel Lobbies
- Courtrooms
- Classrooms
- Retail and grocery stores
- Other low-ceiling applications where clear voice announcements and full range music are required

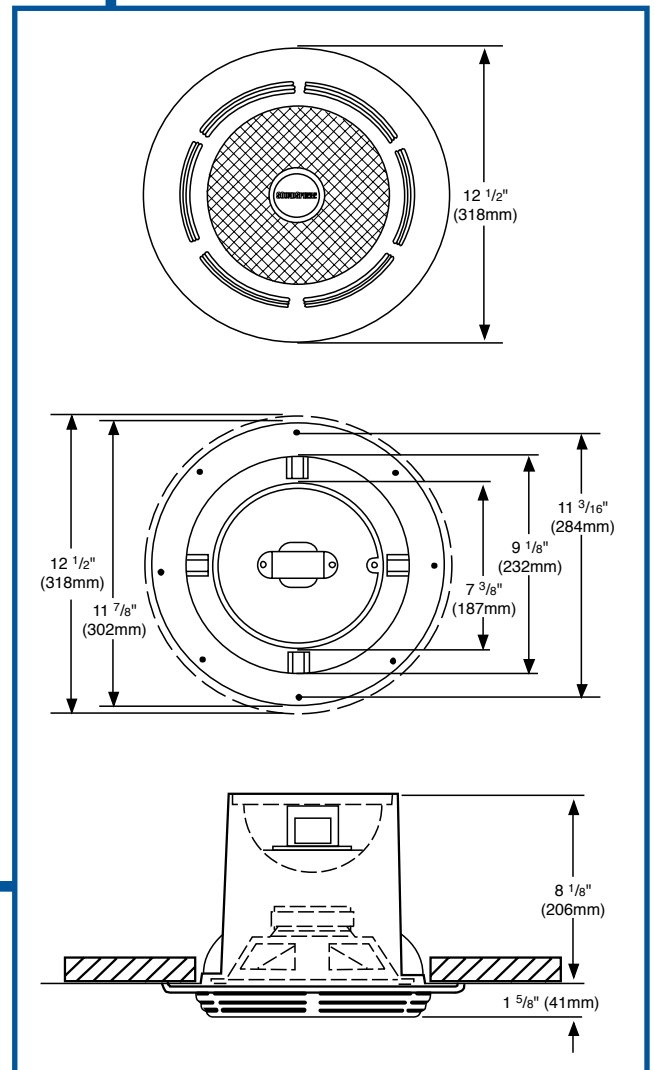

**Specifications:**

**Sensitivity** 89dB 1 Watt/1 meter  
**Maximum SPL** 101dB 15 Watts/1 meter  
**Power Handling** 15 Watts RMS  
**Frequency Response** 55Hz - 16kHz ±4dB  
**Coverage** 180° vertical  
 360° horizontal  
**Available Power Taps** 25V, 70V, 100V  
 15W, 7.5W, 3.8W, 1.9W,  
 1W, 0.5W  
**Weight** 7.25 lbs. (3.3 kilos)  
**Size** Enclosure: 7 3/8" dia x 8 1/8" high  
 (187mm x 206mm)  
 Mounting Flange: 11 7/8" dia (302mm)  
 Grille: 12 1/2" dia x 1 5/8" high  
 (318mm x 41mm)  
**Driver** Coaxial: 8" LF,  
 1/2" dome HF  
**Enclosure Material** ABS Resin

**Spacing in Multiple Loudspeaker Systems  
in Feet (Meters)**

Floor to Ceiling Height in Feet (Meters)	Direct Field SPL Variation in dB				
	3 (±1.5)	4 (±2.0)	5 (±2.5)	6 (±3.0)	
8 (2.5)	14 (4.3)	16 (4.9)	18 (5.5)	21 (6.4)	
10 (3.0)	21 (6.4)	24 (7.3)	27.5 (8.4)	32 (9.7)	
12 (3.7)	27 (8.2)	32 (9.7)	36 (11.0)	42 (12.8)	
14 (4.3)	33 (10.0)	38 (11.6)	45 (13.7)	52 (15.9)	

Based on nominal ear height of 4 feet (1.2M)

Floor to Ceiling Height in Feet (Meters)	Direct Field SPL (dB) vs. Power and Mounting Height					
	Power per Loudspeaker in Watts					
	15	7.5	3.7	2	1	0.5
8 (2.45)	99	96	93	90	87	84
10 (3.00)	95.5	92.5	89.5	86.5	83.5	80.5
12 (3.65)	93	90	87	84	81	78
14 (4.25)	91	88	85	82	79	76

Based on nominal ear height of 4 feet (1.2M)

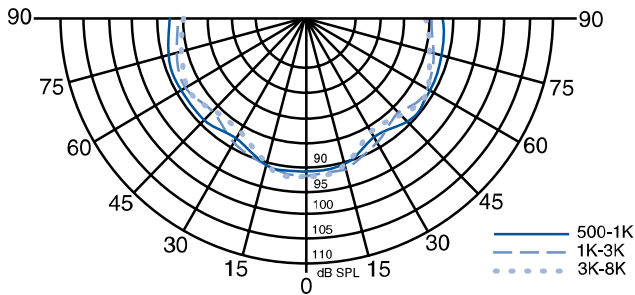

**Vertical Polar Response**

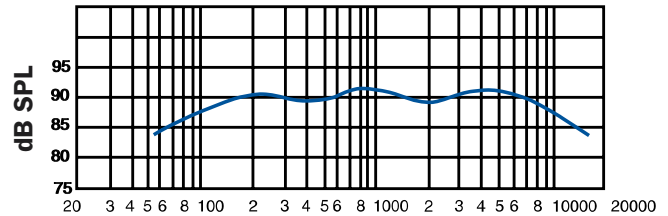

**Hemispherical Power Response 1W/1m**

**Architects and Engineers Specifications**

The loudspeaker shall be a self contained, wide range device with a broad coverage pattern. The frequency response shall be 55Hz to 16kHz ± 4dB; the vertical polar coverage shall be 180° within ± 5dB.

The loudspeaker shall have a minimum sensitivity of 89dB SPL at 1 Watt/1 meter, a continuous power handling capability of 15 Watts, and a rated impedance of 8 ohms. The loudspeaker shall have an integral 15 Watt transformer for 25, 70, or 100 Volt constant voltage systems.

The loudspeaker driver shall be one 8 inch woofer with a 1/2 inch dome tweeter mounted coaxially. The driver shall be mounted in a cylindrical enclosure molded from ABS resin. Hardware shall be stainless or plated steel. An optional steel or aluminum bridge shall be available for supporting the loudspeaker in suspended ceiling tiles. A decorative grille shall be provided.

The loudspeaker enclosure shall measure 7.375 inches (187mm) in diameter and 8.125 inches (206mm) in height. The enclosure mounting flange shall be 11.875 inches (302mm). The decorative grille shall be 12.5 inches (318mm) in diameter and 1.625 inches (41mm) in height. The complete loudspeaker shall weigh 7.25 lbs. (3.3kg).

The loudspeaker shall be the **SoundSphere® Model Q-CS**.

**Warranty**

SoundSphere® loudspeakers are warranted against failure or malfunction due to defects in materials or workmanship for a period of five years from date of original purchase. Defective units will be repaired or replaced at our option if delivered prepaid to our factory. Repaired or replaced units will be returned at our expense. Warranty does not cover appearance or damage caused by abuse, misuse, neglect, accident, or exceeding maximum rated power. Warranty does not cover labor costs involved in removing and/or reinstalling the defective unit, nor any liability due to accidents caused by improper installation. Warranty is extended to original purchaser and is not transferable.